

# THE SCOOTDAWG™ COMPLETE OWNER'S MANUAL FOR GY6 SCOOTERS

This is the manual that should have come with  
your scooter!



For Engines 139QMB and 157QMJ

[www.ScootDawg.com](http://www.ScootDawg.com)  
©2005 ScootDawg.com

## Introduction

This manual is intended as a “real world” manual for all GY6 scooters. This is only a supplement to the manual provided by your dealer or manufacturer. Most of the manuals provided with Chinese scooters are very difficult to understand and most do not have the information you need to properly care for your scooter.

Within these pages you will find instructions for common maintenance procedures. You will also find many specifications that you won't find in common owner's manuals, such as valve gap settings, etc. These values have been obtained from what are believed to be reliable sources but cannot be guaranteed to be correct.

A complete shop manual for the 50cc GY6 can be downloaded at [www.ScootDawg.com](http://www.ScootDawg.com). The vast majority of information also applies to the 125cc and 150cc GY6.

## Safety Warning

Please refer to your original manual for recommended safety precautions. It is up to you to comply with all federal, state and local laws and regulations. Do not operate or work on your scooter under the influence of mind-altering substances. Always wear proper protective gear when riding or working on your scooter. It is recommended that you take a motorcycle safety course if you are a new rider.

**This is copyrighted material. Scootdawg will pursue violators!**

### Table of Contents

#### Page

3	Pre-Delivery Instructions
4	Gauges and Controls
6	Starting/Break-in Procedures
7	Changing the Oil
9	Changing Gear Oil
10	Air Filter
11	Spark Plug
12	Idle Adjustment
13	Carburetor Tuning
14	Brakes
16	Caring for and Storing
17	Maintenance Schedule
18	Torque Settings
21	Valve Adjustment
22	Body Panels
23	Reading Spark Plugs



[www.ScootDawg.com](http://www.ScootDawg.com)

## Pre-Delivery Inspection (P.D.I.)

If you purchased your scooter from a local dealer, they should have already performed a P.D.I. If you purchased it on the internet, you must perform your own. Not doing this can result in malfunction of your scooter and could result in serious injury or death. The following is a typical P.D.I. checklist.

- \*Check all nuts & bolts for tightness
- \*Check fuel lines for kinks and proper connection.
- \*Fully charge the battery before installing. Battery location under the floor

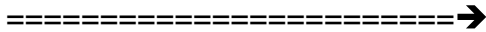

- \*Check spark plug gap. Gap to .035".
- \*Check tire pressure (Improper tire pressure will greatly reduce performance and safety).
- \*Check functioning of all switches and electrical components
- \*Check brake fluid level
- \*Check oil level
- \*Check brake levers for proper free play
- \*Check suspension for proper functioning
- \*Check wheels for alignment, free rotation and proper tightening
- \*Check headlight aim
- \*Check for fuel and oil leakage
- \*Although not common, you may want to consider bleeding your disc brakes. Some owners of less expensive Chinese scooters have reported improperly bled brake lines out of the factory. The easiest and most effective way to do this is to purchase an inexpensive brake bleeding kit at an auto parts store. Follow the instructions with the kit.

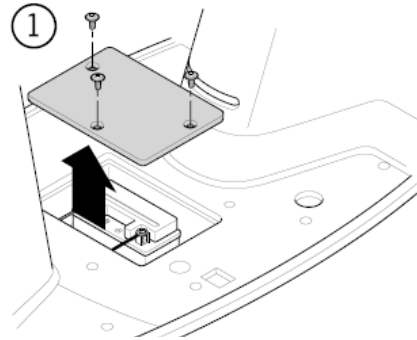

[www.ScootDawg.com](http://www.ScootDawg.com)



## Gauges and Controls

With so many body styles available, the location of your controls may differ and you may have some not included here but this will give a good generic indication of the gauges and controls found on a scooter.

Your controls function as illustrated.

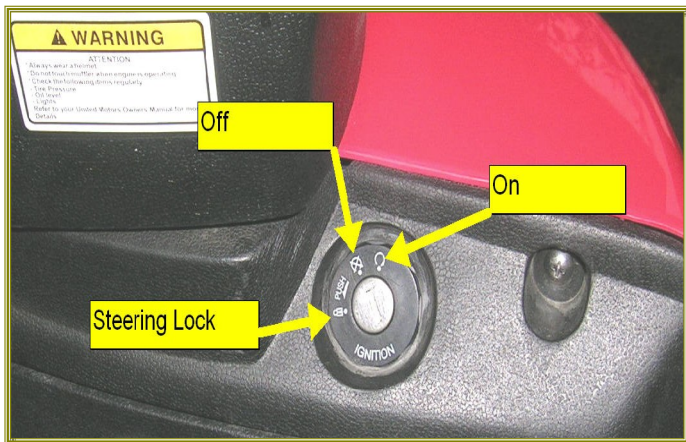
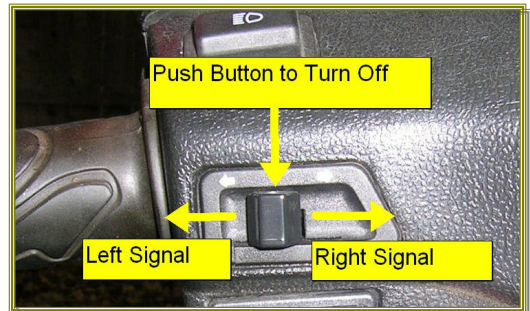
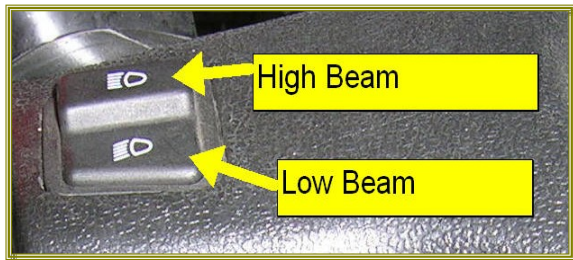
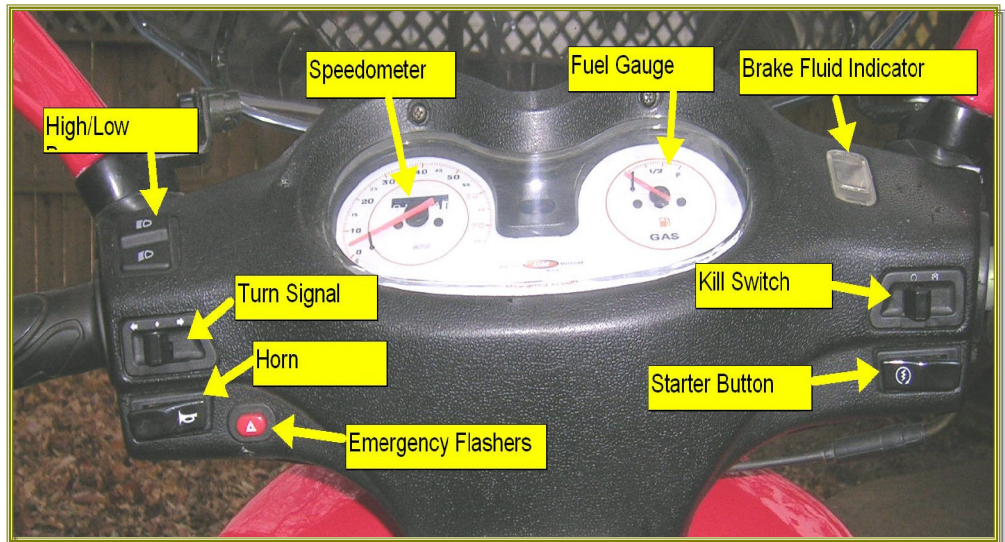

### Ignition Switch:

On Position- Electrical Circuits are on, scooter can be started, key cannot be removed.

Off Position- Electrical circuits are off, engine is off, key can be removed.

To lock steering, turn the handlebars to the left, push the key in and turn it to the lock position.

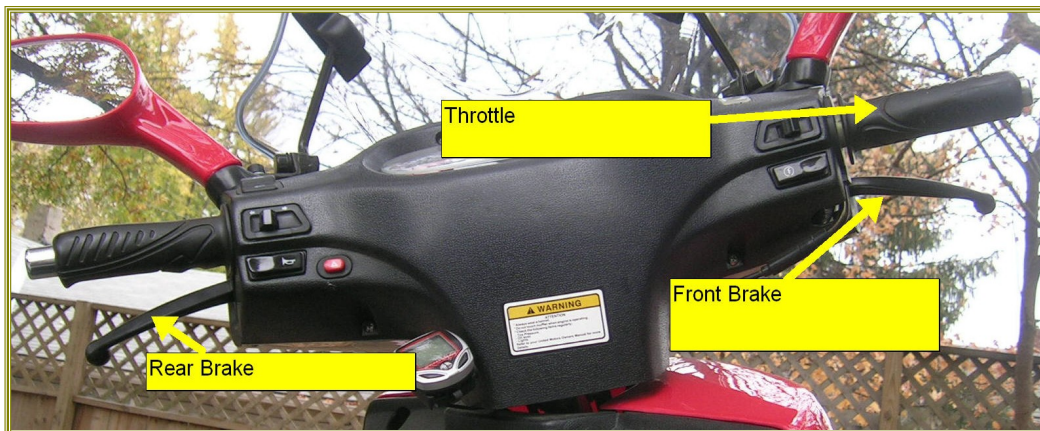
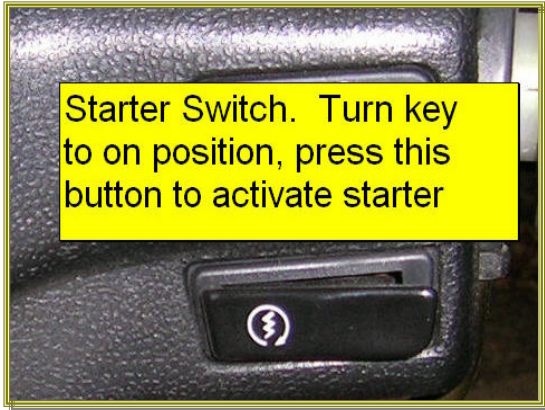

To accelerate, twist the throttle in a counterclockwise motion. When braking, both brake levers should be depressed with even pressure.

## Starting your Scooter

The left brake lever must be held in to start the scooter. Some scooters also come with a safety switch built into the side kickstand and will not start with the side stand in the down position. Make sure the ignition switch is fully on and that the kill switch is in running position.

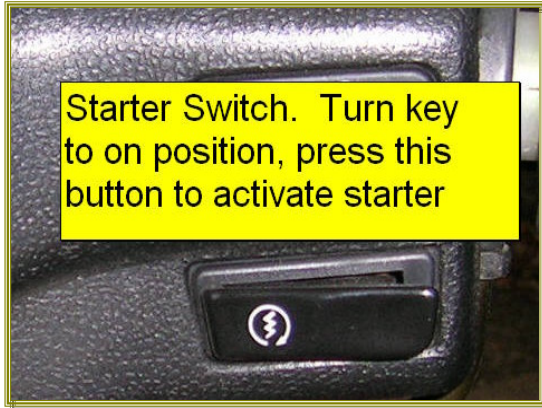

Never leave your scooter running on the side stand. The back wheel could turn and dump your scooter onto the ground.

Never operate the electric ignition more than a few seconds at a time or you will burn the unit out. If you have made more than five repeated attempts to start your scooter, stop and let the starter cool down for a couple minutes.

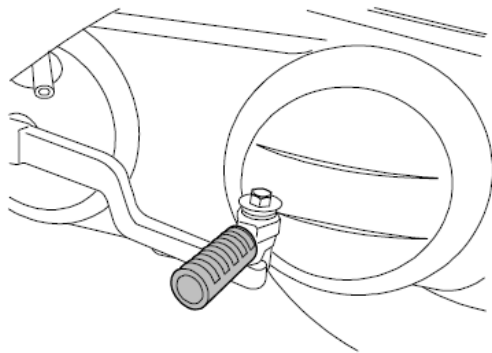

Use the kick starter if the battery is dead. Make sure to return the foot peg to the original position after using. To use the kick, the ignition must be on. Some scooters require that the brake be held in.

## Engine Break-In

Most manufacturers recommend that you not run your scooter at more than 2/3 throttle before it is broken in (around 600-1000 miles). A new school of thought has emerged that many enthusiasts now follow. You can read about the hard break-in method and make your own decision.

[http://www.mototuneusa.com/break\\_in\\_secrets.htm](http://www.mototuneusa.com/break_in_secrets.htm)

The main rule you need to follow is to NOT maintain a constant engine speed for extended periods of time.

[www.ScootDawg.com](http://www.ScootDawg.com)

## Changing the Oil

The oil should at a minimum be changed after the first 300km (180 miles) and every 1000km (600 miles) after that. It doesn't hurt to change it after the first 50 miles. New engines can produce small shavings in the first few miles that can be abrasive to the internal parts.

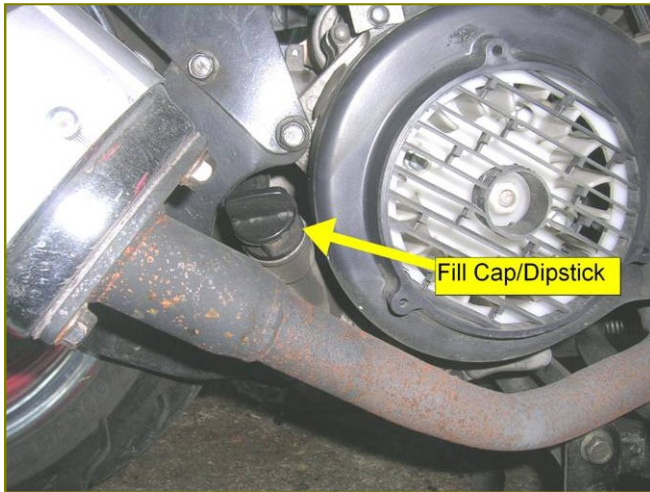

It helps for the engine to be warmed (not hot) at the time of change.

Place a drain pan under the drain plug. Remove the filler cap, then remove the drain plug.

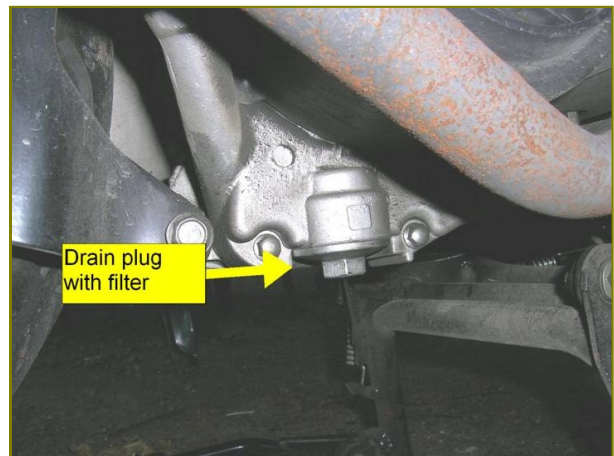

When you remove the drain, these parts will come out 5=screen filter, 6=spring, 7=gasket, 8=plug.

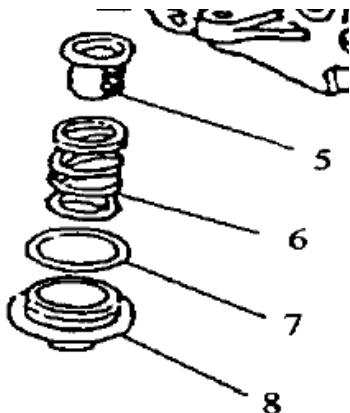

Blow out the screen with compressed air to clean.

Gently depressing the kick starter five or six times will flush out remaining oil that does not drain freely. Make sure the ignition switch is in the off position while doing this.

After oil is thoroughly drained, replace plug components in the configuration shown.

Fill oil as shown using a funnel. Use high quality 10w40 or 5w30 synthetic oil.



Capacity is approximately 0.9 liter. Check the level using the dipstick. Do not screw the dipstick in while checking the level. Do not overfill.



Replace filler cap. Check for leaks. Take a short ride and check the level and for leaks again.

[www.ScotDawg.com](http://www.ScotDawg.com)



## How to Change Gear Oil

Tools you will need

1. 10 mm wrench
2. Pistol grip oil can
3. 75w90 gear oil 110cc (3.7 oz.)
4. Measuring cup.

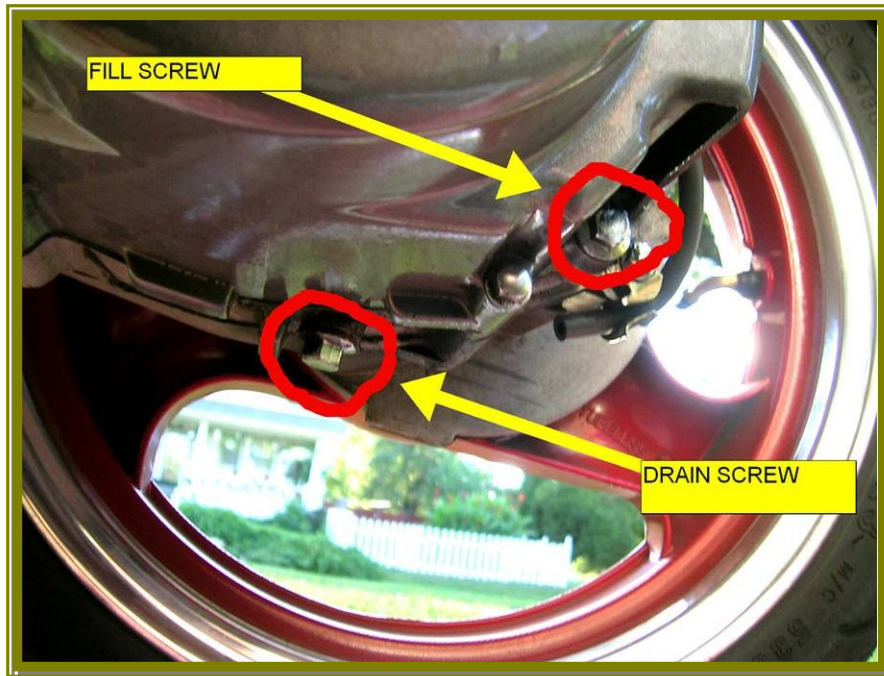

Do the following while the scooter is warmed (not hot). Measure 110cc (3.7 oz) of gear oil into a measuring cup. Pour the oil into the pistol grip oil gun. Spread a towel under the drain plug and place measuring cup under drain screw. Remove the drain screw and fill screw and let oil flow out into

the measuring cup. Removing the fill screw at this time helps the oil drain more freely. Using the measuring cup lets you know if you've lost some oil. Once the oil is fully drained, replace the drain screw.

Insert the tube of the oil gun toward the rear of the oil box and squirt the oil gently into the box. Don't squirt so fast that the oil doesn't have time to flow into the box. Once you have emptied the can, replace the fill screw. Wipe everything down and observe for leaks. Take a short ride and observe for leaks again.

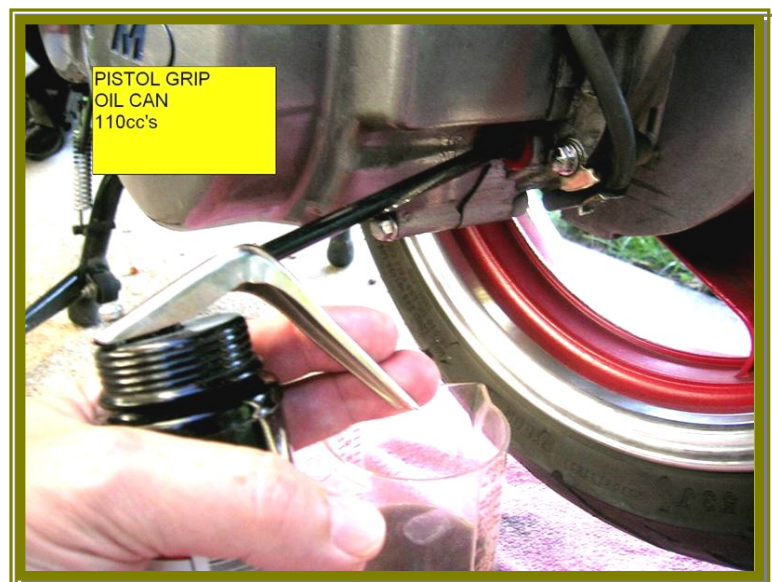

## Air Filter

The air filter on the GY6 scooters is usually found in one of two places. One is on the side next to the kick start. Some models have it located under the seat. Some of the newer models may have it located somewhere else but it should be easy to find.

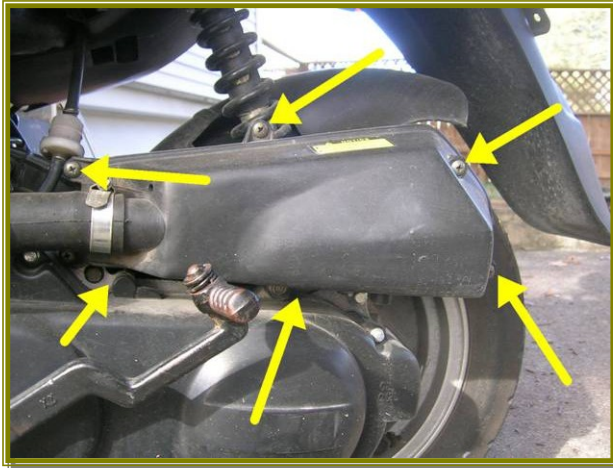

Cleaning the air filter is important. A dirty filter will cause poor performance and decreased fuel economy.

Locate the screws to the plastic cover and remove. The filter is most likely a foam filter which can be cleaned. Some models, such as United Motors, are equipped with filters that need to be replaced.

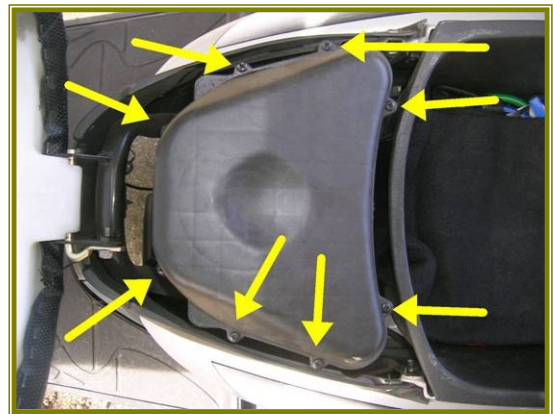

Clean the filter in a pan of kerosene or mineral spirits.

Squeeze out excess solvent. Don't twist or tear the filter. Apply oil to the filter and squeeze out excess oil. The filter should be damp but not wet.



## Spark Plug NGK C7HSA or NGK CR7HSA



The CR7HSA has a resistor to keep radios from buzzing due to the magneto/coil's electrical interference.

The spark plug can be found behind this hatch.

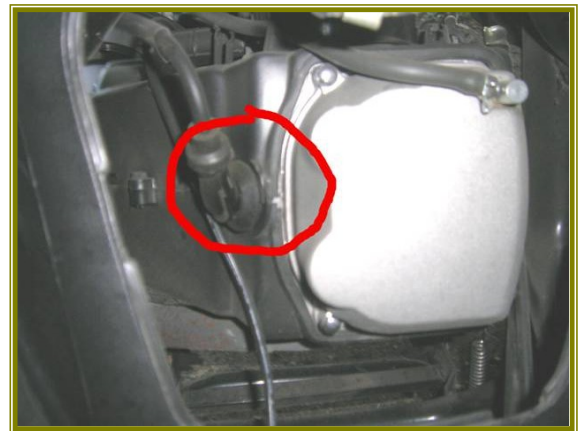

The spark plug should be cleaned every time it is inspected with a small wire brush. The gap should also be checked. Always gap a new spark plug. Most manuals recommend a plug gap of .7 to .8mm (.028" to .032"). Many report better performance at .035".



A chart on how to read your plug is included at the end of this manual.

## Idle Speed Adjustment

150cc=1400rpm +/-

50cc=1900rpm +/-

Engine idle speed should be adjusted to 1400 rpm for the 150cc and 1900 rpm for the 50cc. However, when the scooter is new, it may need to be adjusted a little higher until the engine breaks in to prevent dying at stop lights, etc. If you don't have a tachometer you can adjust by ear. The idle should be adjusted just high enough so that when set on the center stand with rear wheel elevated, the wheel turns very slowly. Adjusting the idle is a very simple procedure.

The easiest way to get to the idle screw is to remove the well under your seat. Locate the screws and/or nuts securing the well and remove them. On most models, the gas cap must also be removed.

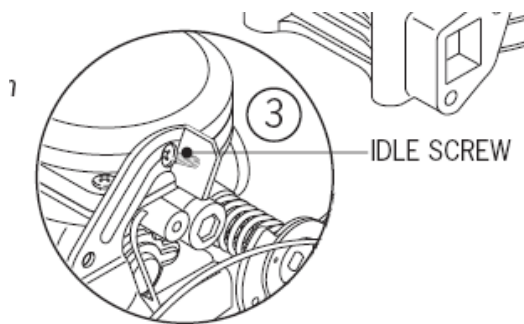
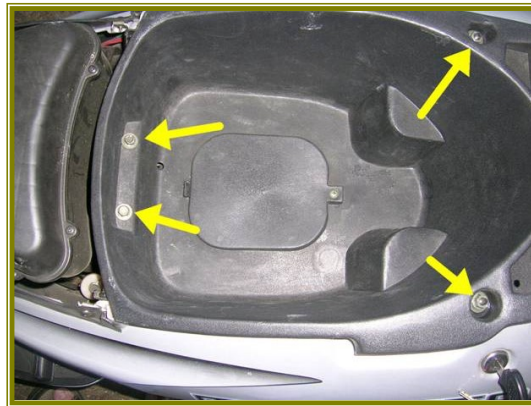

Turn the screw clockwise to increase the idle, counterclockwise to decrease the idle.

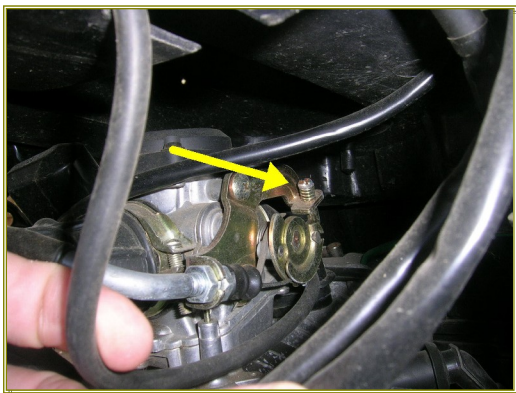
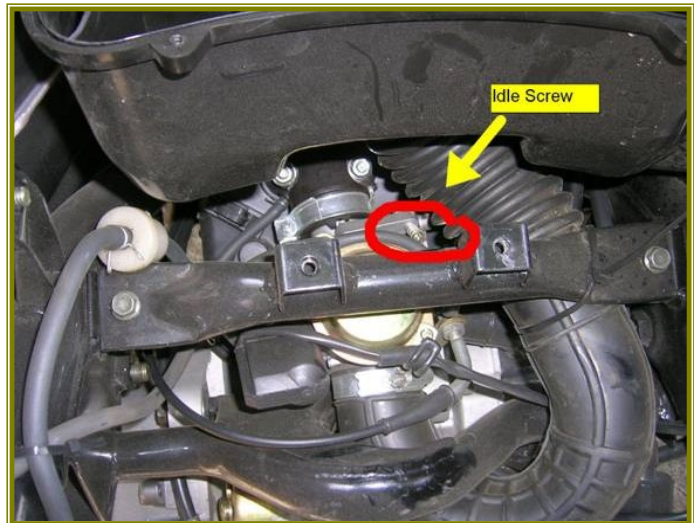

## CARBURETOR TUNING

It is rare that this procedure is needed, usually after major modifications to the engine or if you live in a very high altitude location.

This procedure should be performed with the engine warmed.

1. Adjust idle to 1400 rpm for 150cc or 1800 rpm for the 50cc with idle screw.

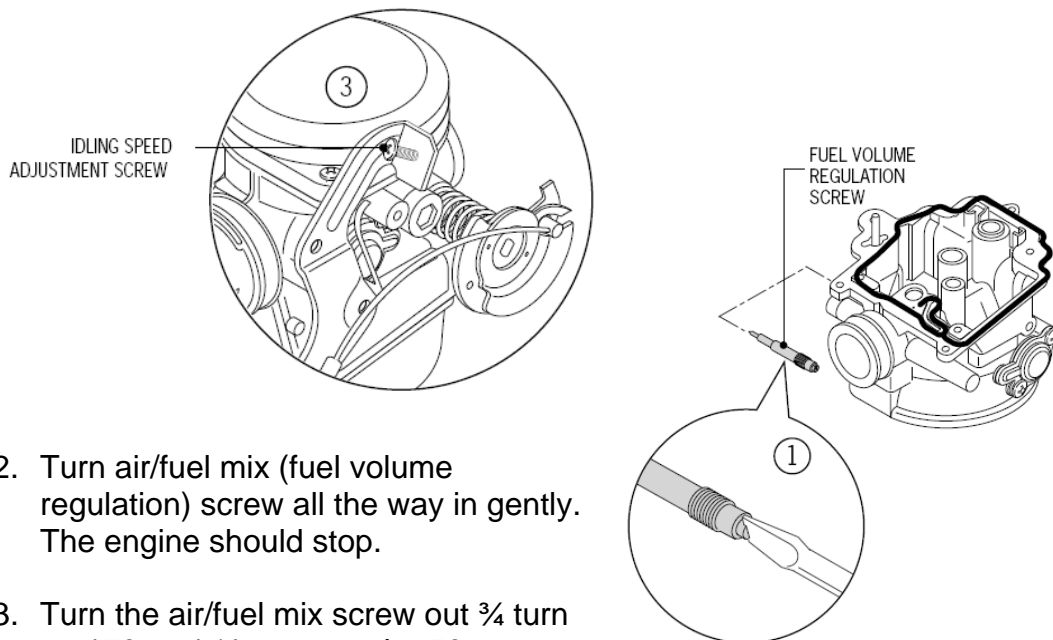

2. Turn air/fuel mix (fuel volume regulation) screw all the way in gently. The engine should stop.
3. Turn the air/fuel mix screw out  $\frac{3}{4}$  turn on 150cc,  $1 \frac{1}{2}$  turns on the 50cc.
4. Start engine and increase idle (with idle screw) to a fast idle.
5. Slowly turn the air/fuel mix screw out until maximum idle speed is achieved.
6. Readjust idle screw to proper idle speed.
7. Check for stability by accelerating a few times. If engine doesn't accelerate smoothly, readjust.

## Brakes

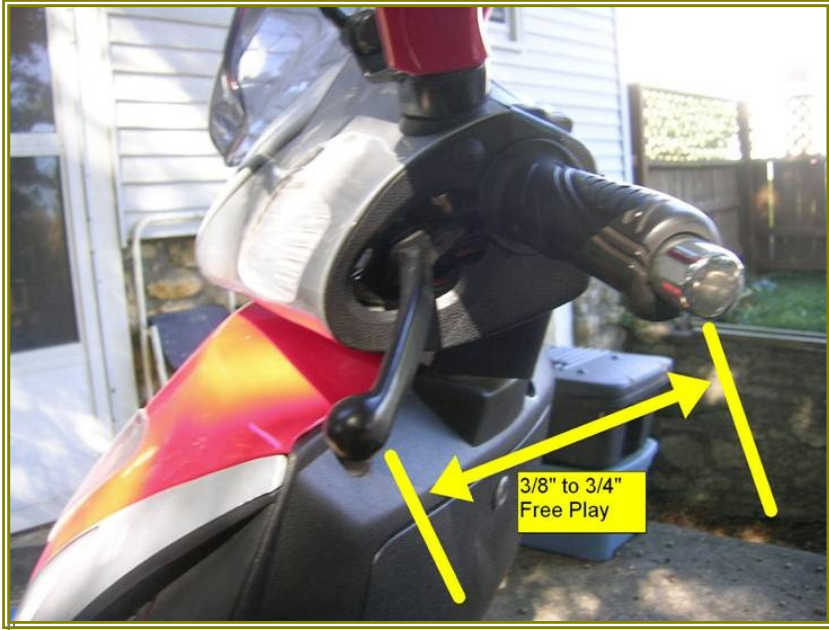

### Rear Drum Brakes

If you have more than  $\frac{3}{4}$ " free play or feel the handle "bottom out", you need to adjust your brake.

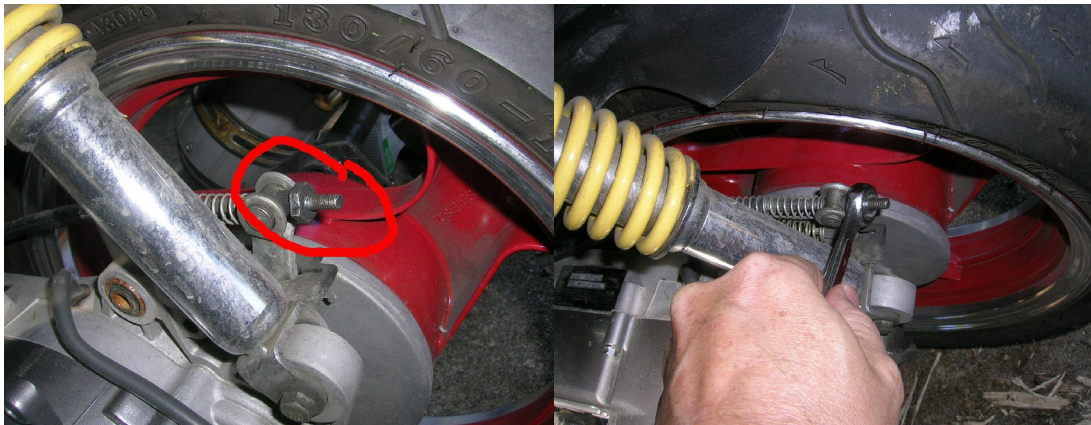

Turn the adjusting nut clockwise for a tighter adjustment. Make sure that the concave side of the adjusting nut is seated securely on the pin. Adjust inward until free play is  $\frac{3}{8}$ " to  $\frac{1}{2}$ ". After adjusting, spin the wheel to make sure it spins freely. Test ride and adjust again if necessary.

## Front (and Rear) Disc Brakes

Locate the window to observe brake fluid level. Make sure master cylinder is level by placing the scooter on the center stand and centering the handlebars.

If the fluid level is low, inspect the brake pads for excessive wear. If the pads are ok, you are probably leaking fluid. Replenish fluid with DOT 3 to proper level. Brake fluid WILL damage the finish on your scooter if you spill it.

Unless you have the necessary mechanical skills, leave more complicated brake work to a professional.

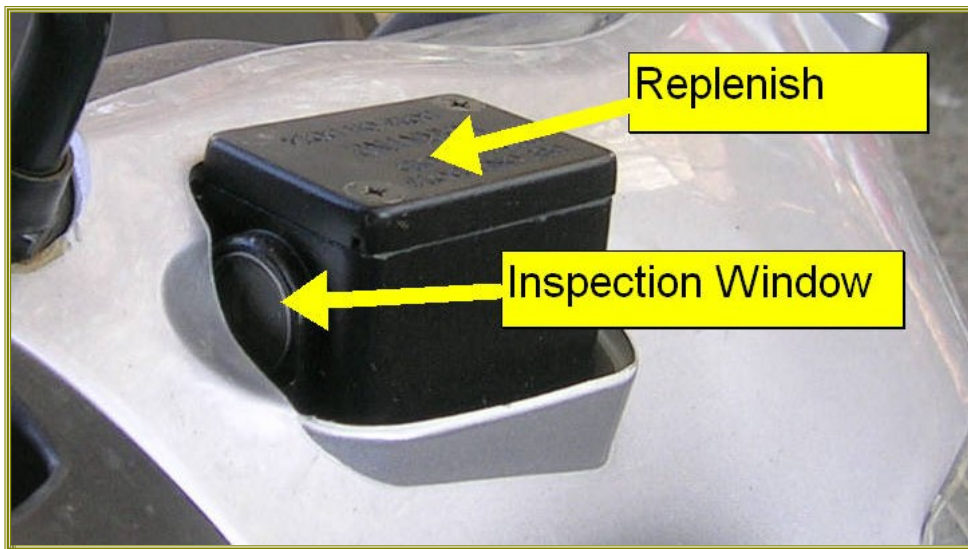
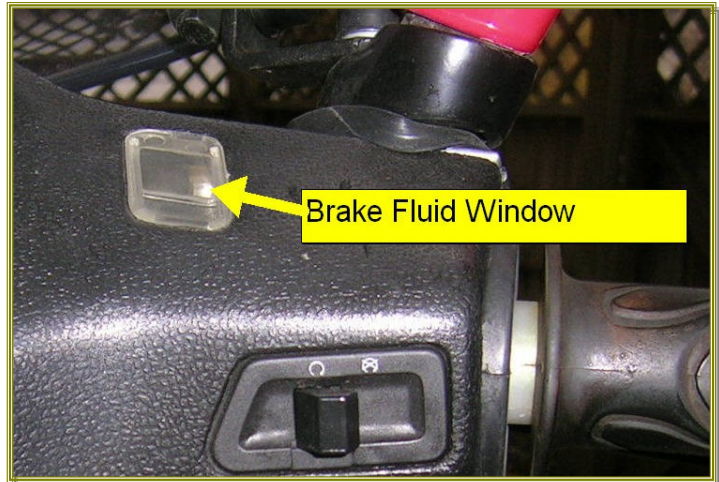

## Caring for and Storing Your Scooter

If you are going to store your scooter for extended periods, such as over winter months, it is important that you do a little preparation. Add a fuel stabilizer to your fuel such as Stabil™. This will prevent your fuel from becoming unstable and causing damage to the internal parts of your fuel system. Old fuel can gum up your carburetor and clog your jets. When you add the stabilizer, it is important to run the engine enough to get the stabilizer worked into the entire system.

The use of a float charger will keep your battery in top condition. Many scooterist and motorcycle riders keep a float charger attached whenever the bike is not in use. This will extend the life of your battery and you won't be surprised with a dead battery at an inconvenient time. A float charger will not overcharge and destroy your battery and can be left on for indefinite periods of time. Any other type of charger left attached to the battery too long will damage or destroy it. An inexpensive float charger like the one pictured to the right can be purchased for under \$15 at places like Harbor Freight™. Some opt for more expensive ones like Battery Tender™ that have options for installing a simple plug in.



It is best to store a scooter in a garage or shed to protect it from the elements. If this isn't possible, use a good quality scooter cover. It is important that a cover allows air circulation so that moisture doesn't condense on the on the scooter and cause premature rusting and possible damage to the electrical system.

Wrong way to store scooter!



## Maintenance Schedule

This schedule may not match that which came with your scooter. It is very close to most of them. If you have warranty issues, you should follow the recommended schedule that came with your scooter.

### Maintenance Chart

Perform regular maintenance, according to maintenance handbook.

I: Inspect, clean, lubricate, add fix or replace when necessary.

A: Adjust B: Clean C: Replace D: Tighten

Item	Frequency	Whichever comes first	Mileage (Km)											
			km 1000 mi 620	km 2000 mi 1240	km 3000 mi 1860	km 4000 mi 2480	km 5000 mi 3100	km 6000 mi 3720	km 7000 mi 4340	km 8000 mi 4960	km 9000 mi 5580	km 10000 mi 6200	km 11000 mi 6820	km 12000 mi 7440
Engine oil			the first 300km/ 186 mi	R	R	R	R	R	R	R	R	R	R	R
Engine oil filter			300km/ 186 mi			C					C			
Fuel filter screen											R			
Gear oil	Note 3		new R 300km/ 186 mi				R				R			
Valve gap				A		A				A				A
Carburetor						I				I				I
Air filter	Note 2, 3		I				R					R		
Spark plug			Clean every 3000Km Replace when necessary											
Brake system				I	I	I	I	I	I	I	I	I	I	I
Drive belt										I				
Suspension						I				I				I
Screws and nuts										I				
Tire						I								I
Steering stem bearing			I					I						I

•For safety reasons, it is recommended that service be performed by a dealer.

### Note:

1. For mileage higher than what is specified in the chart, the maintenance should be repeated at the same interval listed.

2. More frequent maintenance is required if the vehicle is used in dusty areas or in rain.

3. More frequent replacement is required if the vehicle is subjected to sever use, such as heavy load operation, long trips or operation in rain.

## Torque Settings for 50cc Scooter

### Torque Settings

#### Standard Torque Settings

General Torque Requirements for Standard Fasteners

Fastener Type	Torque	Fastener Type	Torque
5mm Cap Screw	.5 kg/cm	5mm Socket Head Screw	.4 kg/cm
6mm Cap Screw	1 kg/cm	6mm Socket Head Screw	.9 kg/cm
8mm Cap Screw	2.2 kg/cm	8mm Flange Head Screw	1.2 kg/cm
10mm Cap Screw	3.5 kg/cm	10mm Flange Head Screw	2.7 kg/cm
12mm Cap Screw	5.5 kg/cm	12mm Flange Head Screw	4.0 kg/cm

#### Special Torque Settings

Torque Requirements for Engine Fasteners

Fastener Type	Number Used	Dia. (mm)	Torque kg m (in. lbs)	Comments
Cylinder Bolt A	2	8	.9	
Cylinder Bolt B	2	8	.9	
Oil Filter Screen Cap	1	30	1.5	
Exhaust Pipe Flange Bolt	2	6	.9	
Flange Screw Belt Pulley	4	8	2.0	Lubricate with Engine Oil
Valve Adjusters	2	5	.9	Lubricate with Engine Oil
Cam Chain Adjuster	1	6	1.0	
Guide Plate Screw / Oil Fill Screw	1	8	1.3	
Clutch Cover Screw	1	12	5.5	
Clutch Driven Unit Mounting Screw	1	12	5.5	
Starter Motor Mounting Screw	2	6	1.0	
Oil Pump Mounting Screw	3	6	1.2	
Clutch Driver Mounting Screw	1	12	5.5	
ACG coil Mounting Screw	3	6	1.0	
Cam Chain Adjuster Screw	1	6	.5	
Spark Plug	1	10	1.2	

Torque Requirements for Frame Fasteners

Fastener Type	Number Used	Dia. (mm)	Torque kg m (in. lbs)	Comments
Cylinder Bolt A	1	25.4	8-12	
Cylinder Bolt B	1	10	4-5	
Oil Filter Screen Cap	1	14	8-10	
Exhaust Pipe Flange Bolt	1	10	3-4	
Flange Screw Belt Pulley	1	8	2-3	Use Soft Set Lock-Tite
Valve Adjusters	1	5	.5	

## Torque Settings 150cc Scooter

**It is Important For The Components / Fasteners To Be Tightened As Per Specified Torque**

NO.	NA ME	QTY	TORQUE
1	Tapping screw for fan cover assy.	2	1-3NM
2	Screw for fan cover assy.	2	10-12NM
3	Tapping screw for top and bottom guide fan cover	3	1-3NM
4	Screw for top and bottom guide fan cover	1	10-12NM
5	Tapping screw and nut for ventilating air chamber of cylinder head cover	3	1-3NM
6	Bolt for cylinder head cover	4	10-12NM
7	Nut for double head blot on cam fixing holder	4	22-25NM
8	Nut for chain guide	1	10-12NM
9	Screw for chain adjustor	2	10-12NM
10	Bolt for cylinder head	2	10-12NM
11	Bolt for cylinder	1	10-12NM
12	Spark plug	1	10-15 NM
13	Double head bolt for cylinder head inlet port	2	10-12NM
14	Double head bolt for cylinder head exhaust port	2	10-12NM
15	Nut for carburetor joint pipe	2	10-12NM
16	Screw for cooling fan	4	10-12NM
17	Screw for flywheel	1	45-55NM
18	Nut for magnet Assay	2	6-8NM
19	Screw for pick up coil	2	10-12NM
20	Nut for right crankcase cover	9	10-12NM
21	Oil filter cover cap	1	55-60NM
22	Nut for oil pump	2	10-12NM
23	Nut for oil pump sprocket	1	8-10NM
24	Nut for oil pump	2	10-12NM
25	Nut for oil pump cover	1	1-3NM
26	Screw for starting-clutch	1	35-40NM
27	Screw for super starting clutch outside	3	10-12NM
28	Bolt for right crankcase	2	10-12NM
29	Double head bolt for left and right crankcase	4	22-25NM
30	Fixing bolt for self start motor	2	10-12NM
31	Bolt for left crankcase cover and wiring harness	11	10-12NM
32	Tapping screw for ventilating guide board of left crankcase cover	4	3-6NM
33	Nut for drive disc	1	45-55NM
34	Nut for driven disc	1	45-55NM
35	Nut for driven disc clutch	1	55-60NM
36	Nut for press-board of kick starter	1	10-12NM
37	Bolt for transmission case cover	5	10-12NM
38	Bolt for transmission case cover	2	22-25NM
39	Nut for oil hole of left crank shaft.	1	40-45NM
40	Nut for position shaft of left crank shaft	1	22-25NM

## TORQUE SETTINGS 150CC

### INSTALLATION OF VEHICLE BODY

#### Specified Torque Value

NO.	ITEM	QTY.	TORQUE
<b>FRONT WHEEL/FRONT ABSORBER</b>			
1	Front wheel axis locknut	1	55-62Nm
2	Fixing bolt between front absorber and support under connecting board assy.	4	37-44N.m
3	Fixing bolt for disc brake and front absorber	2	22-29N.m
<b>Handlebar</b>			
1	Fixing bolt for handlebar and supporting under connecting board	1	37-44N.m
<b>Frame</b>			
1	Fixing bolt for frame and engine bracket	2	37-44N.m
2	Fixing bolt for frame and rear absorber	2	37-44N.m
<b>Rear wheel/rear absorber</b>			
1	Rear wheel locknut	1	100-130Nm
2	Fixing bolt for left, rear absorber and engine	1	22-29N.m
3	Fixing bolt for right, rear absorber and muffler connecting board	1	22-29N.m
<b>Engine</b>			
1	Fixing bolt for engine and muffler	2	22-29N.m
2	Fixing bolt for engine and engine bracket	1	37-44N.m

## Valve Adjustment

The valve gap on the 150cc scooters is 0.0019 inches on intake valve and 0.0024 inches on the exhaust valve. The following diagram has the valve clearance on the 50cc scooters.

### Valve Adjustment

- Always check and adjust with engine temperature lower than 35°C (95°F)

1. Remove cylinder head cover.
2. Rotate cooling fan to camshaft. Locate mark at center top, aligning magneto fly wheel mark with that on crankcase. Magneto "T" mark and box crankshaft mark.

**Valve gap checking and adjustment valve gap:**  
IN: 0.05mm (.00197 in.)  
EX: 0.05mm (.00197 in.)

3. To adjust the valve gap, loosen jam nut and rotate adjusting nut.

### Valve Adjustment Wrench

- Be sure to check valve gap again, after locking jam nut.

### Carburetor Idle Speed

- Idle adjustment should be made with the engine warmed up.

1. Remove cover.
2. After the engine warms up, connect it to an engine revolution counter.
3. Adjust idle screw until specified revolution is obtained.

*Minimum idling speed: 1900+190rpm*

4. Readjust the screw if the idle speed is not steady or fuel cannot be properly applied.

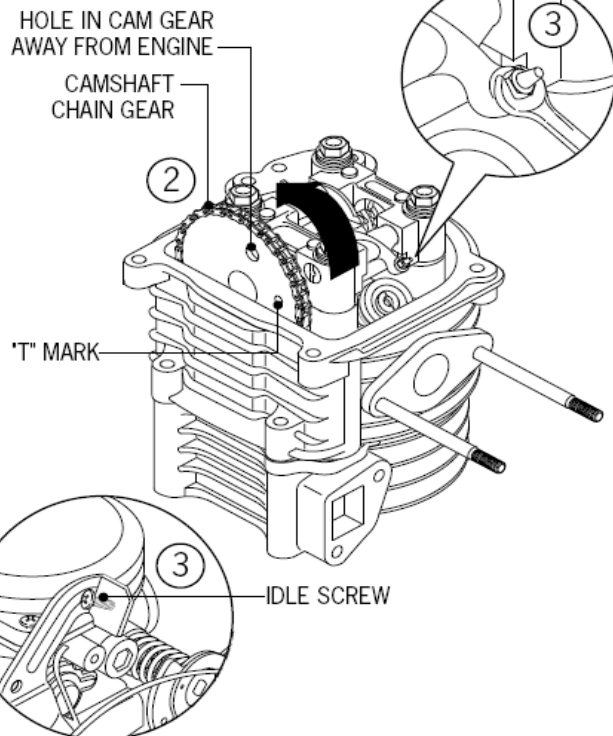
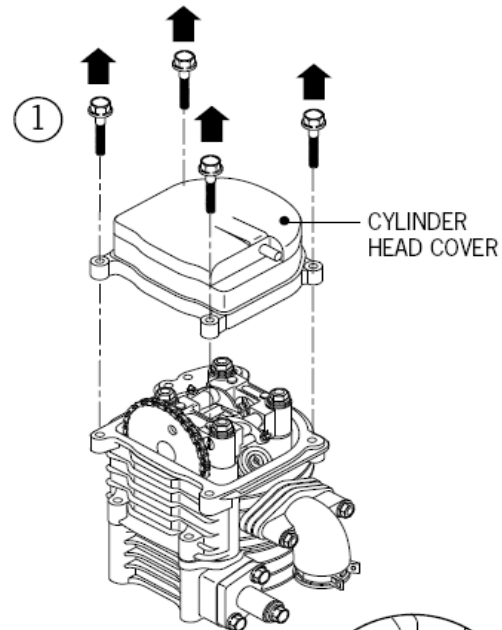

## Body Panels

Body panels can be tricky to remove but there are a few tricks. The main thing is to be patient and smart. Don't force anything. The following series of photographs is removing the front panel to replace headlight bulbs.



The first order of business is to locate the most likely screws that are securing the panel. Sometimes they are well hidden. In this case, they are fairly straightforward.

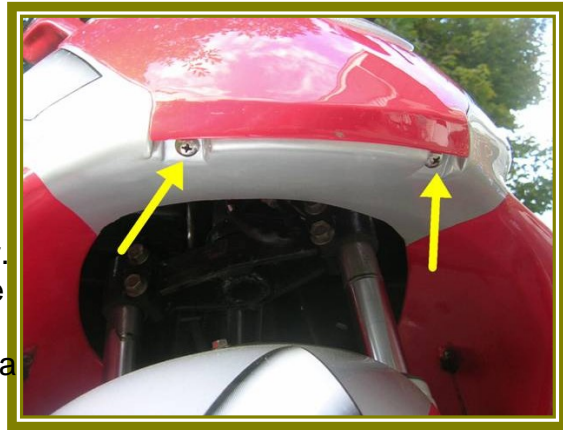

Next, gently pry at the panels and try to find tabs or other forms of fitting together. Never force it. Sometimes you find more screws. Sometimes the panel needs to be squeezed or you may need to slide it a certain direction. Often the tabs are formed to fit together like a puzzle. You make want to take pictures or make some sort of record of how you have removed a panel and keep it in your "scooter" file. Three years from now you may need to remove the panel again.



## Reading Spark Plugs

The following information is directly from the NGK website.



### Normal Condition

An engine's condition can be judged by the appearance of the spark plug's firing end. If the firing end of a spark plug is brown or light gray, the condition can be judged to be good and the spark plug is functioning optimally



### Dry and Wet Fouling

Although there are many different cases, if the insulation resistance between the center electrode and the shell is over 10 ohms, the engine can be started normally. If the insulation resistance drops to 0 ohms, the firing end is fouled by either wet or dry carbon.



### Overheating

When a spark plug overheats, deposits that have accumulated on the insulator tip melt and give the insulator tip a glazed or glossy appearance.



#### **Deposits**

The accumulation of deposits on the firing end is influenced by oil leakage, fuel quality and the engine's operating duration.



#### **Lead Fouling**

Lead fouling usually appears as yellowish brown deposits on the insulator nose. This can not be detected by a resistance tester at room temperature. Lead compounds combine at different temperatures. Those formed at 370-470°C (700-790°F) having the greatest influence on lead resistance.



#### **Breakage**

Breakage is usually caused by thermal expansion and thermal shock due to sudden heating or cooling.





#### **Normal Life**

A worn spark plug not only wastes fuel but also strains the whole ignition system because the expanded gap (due to erosion) requires higher voltages. Normal rates of gap growth are as follows:

*Four Stroke Engines:* 0.01~0.02 mm/1,000 km (0.00063~0.000126 inches/1,000 miles)

*Two Stroke Engines:* 0.02~0.04 mm/1,000 km (0.000126~0.00252 inches/1,000 miles)



#### **Abnormal Erosion**

Abnormal electrode erosion is caused by the effects of corrosion, oxidation and reaction with lead - all resulting in abnormal gap growth.



#### **Melting**

Melting is caused by overheating. Mostly, the electrode surface is rather lustrous and uneven. The melting point of nickel alloy is 1,200~1,300°C (2,200~2,400°F).



#### **Melting**

Melting is caused by overheating. Mostly, the electrode surface is rather lustrous and uneven. The melting point of nickel alloy is 1,200~1,300°C (2,200~2,400°F).



#### **Lead Erosion**

Lead erosion is caused by lead compounds in the gasoline which react chemically with the material of the electrodes (nickel alloy) as high temperatures; crystal of nickel alloy fall off because of the lead compounds permeating and separating the grain boundary of the nickel alloy. Typical lead erosion causes the surface of the ground electrode to become thinner, and the tip of the electrode looks as if it has been chipped.